

REV	DESCRIPTION	DRAWN	DATE

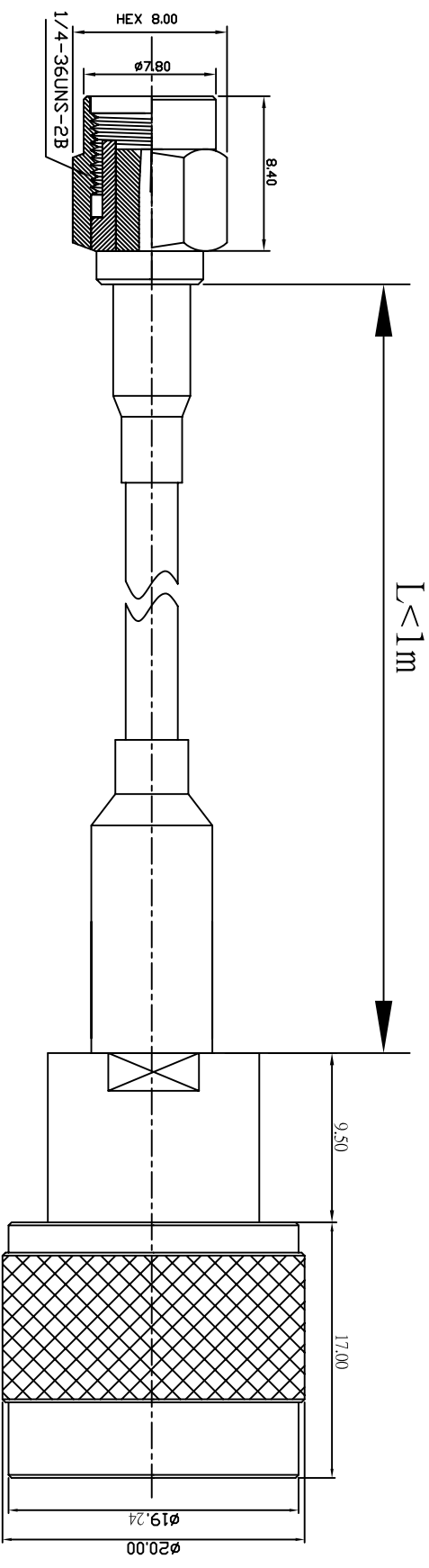

NO	Description	Qty	Material	Finish
3	N-1158-2-L-TGN	1	BRASS	NICKEL
2	RG174/RG316/LLC100	1		
1	SMA-1001-3-RP-L-TGG	1	BRASS	GOLD

UNLESS OTHERWISE SPECIFIED		*MAJOR DIMENSION		APPROVED	
1 REMOVE ALL BURRS		UNLESS OTHERWISE		CHECKED	
2 BREAK ALL CORNERS & EDGES TO 1.5 MAX.		NOTED TOLERANCES		DRAWN	
3 CHAMFER 1ST & LAST THREADS 45°		0.5-6 = ±0.2		PEN	
4 DIAMETERS ON COMMON CENTERS TO BE CONCENTRIC WITH DIMENSIONS ARE AFTER PLATING.		6-30 = ±0.4		DRAWN DATE 04/09/29	
		30-120 = ±0.6		FILE NDN\DWG\SMA1001-N1158\10013R\174\316\100\11582-1L	
		120-315 = ±1.0		TITLE	
		ANGLES = ±1°		SMA1001-N1158	
		SCALE 3/1		DRAWING NO. 10013R/174/316/100/11582-1L	
		UNIT MM		REV A	

華耀科技有限公司
 Hua Yao Technologies co., Ltd